

Step #1

Position the spa cover (in closed position) on the spa making sure that all four corners are properly positioned and square on the spa.

Step #2

Install the wind lock bar on the determined bracket side, (See Fig. 1) **Note: lightly tighten nut, washer and bolt combination so that the lock bar moves freely.**

Step #3

Install the metal plate, rubber stops, bolt assembly and ball studs, (See Fig.1). **Note: The metal plate MUST be installed on the inside of the bracket that the Wind Lock Bar is attached to. Lightly tighten bolt assembly, overtightening will cause plastic to disfigure, not allowing the cover plates to snap on properly.** Place the two Large Plastic Dome Caps over the 3/8" locknuts.

Step #4

Using the #12 x 2" screws, attach the left and right mounting brackets, 4" from the lip of the spa, to the appropriate sides of the spa (see Fig. 2)

Step #5

Starting with the left side first, lay the long end of the cover support arm on the top of the cover, lying parallel to the spa cover hinge about 1/2" away. Slide the U-shaped retainer clip between the two cover halves with the horizontal part touching the underside of the cover hinge. **Note: Do not insert the U-shaped retainer clip in between the seams of the spa cover.** (see Fig. 3) With the left support arm lying on the cover, slide the straight coupler piece over the long end of the left cover support arm. Next, slide the long end of the right support arm into the center coupler and slide the U-shaped retainer clip between the two cover halves.

Step #6

Slide the left and right pivot arms onto the short end of the support arms (See Fig. 3) **Note: Do not insert self-tapping screws at this time, this will be completed in step #8.** Next connect the Pivot Arms to the Brackets (See Fig. 1). Be sure to run the Hex Cap Screws as pictured. **Lightly tighten the nut so the pivot can move freely.**

Step #7

Next, install the ball studs to the left and right pivot arms. Place the two Hex Dome Caps over the Ball Stud Lock Nuts. **Note: Be sure that the ball is pointing away from the spa.** (see Fig. 4).

Step #8

With the coupler piece and support arms adjusted properly (about 1/2" away from cover hinge and centered on spa), using the #10 self tapping screws, fasten support arms to pivot arms and center coupler piece to the support arms (see Fig. 5). **Note: Be sure to rotate the coupler piece so that the inserted screws are at a horizontal angle with the screw head facing the back of the spa.**

Step #9

Using the Covermate, lift the cover off the spa and place it in the upright position. Snap the gas shocks on the ball studs. **Note: Be sure to install Gas Shocks with the black body on top.** (see Fig. 6 for complete look).

Step #10

Attach the 3/8" Rubber Sleeve to the end of the Pivot Arm that the Wind Lock Bar latches onto. (see Fig. 7). Attach the provided 3 hook TowelMate on the preferred side of your Covermate by simply snapping it into place and inserting the middle self tapping screw (see Fig. 8).

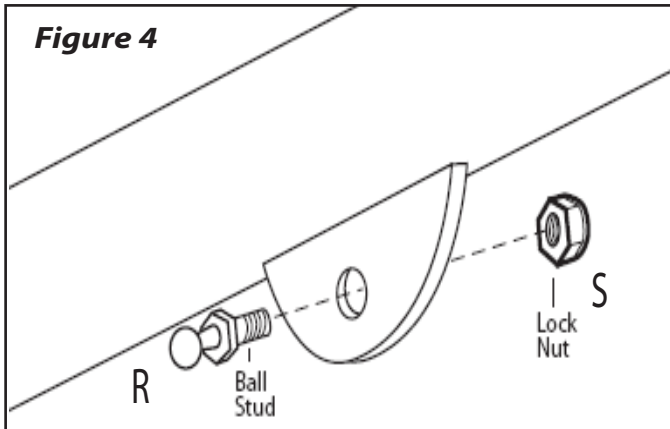
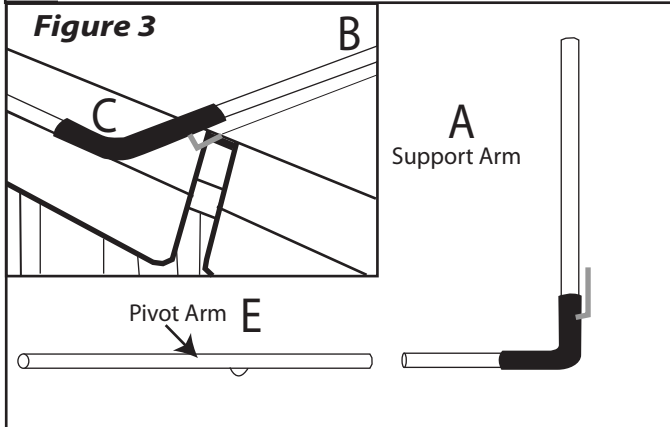
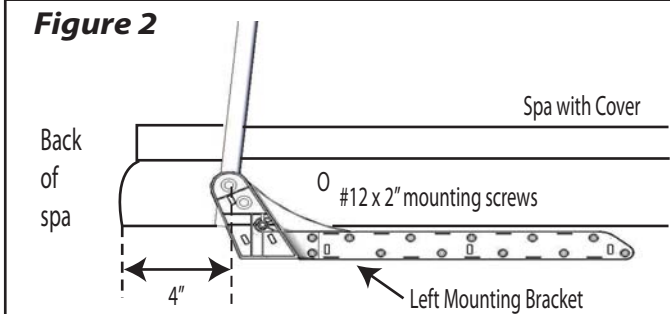

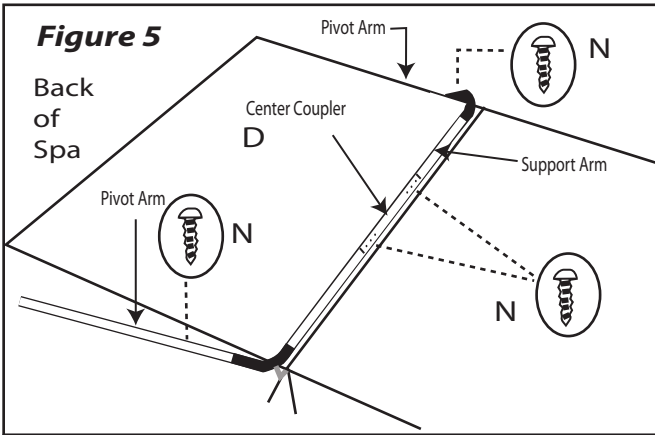

Figure 6

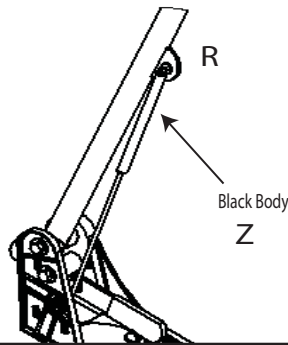

Figure 7

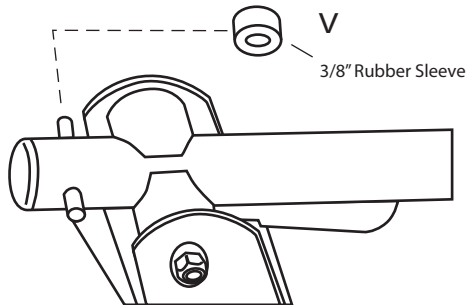

Figure 8

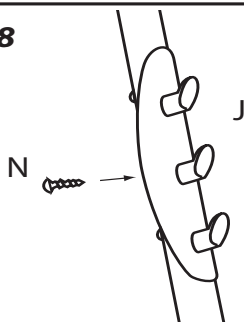
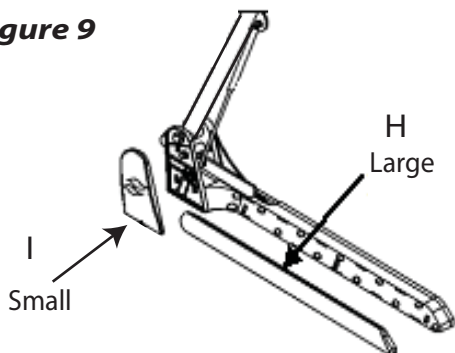

Figure 9



Step #11

Snap on the left and right bracket covers (small and large covers) (see Fig. 9).

Operation of the Covermate III Plastic

1. Fold the first half of the spa cover off the spa. Gripping the foam grip. Motion the spa cover into its vertical upright position
2. **Important: when closing the spa cover always unlock the Wind Lock Bar by lifting up on the larger bar and pulling the Covermate down to prevent possible lift damage.**

CAUTION!

Do not use the Covermate in high wind condition (greater than 10 m.p.h). Injury from the spa cover being blown over and impacting the spa user can occur.

ITEM	PART#	DESCRIPTION	QTY
A	100028	SUPPORT ARM W/RETAINER-RIGHT - 20" X 40"	1
B	100029	SUPPORT ARM W/RETAINER-LEFT - 20" X 40"	1
C	100002	FOAM GRIP - 8"	2
D	100003	CENTER COUPLER 3'7" X 1-1/8"	1
E	100022	PIVOT ARM 2'7" X 1-1/4"	2
F	100344	BUSHING .8825" THICK	4
G (L)	100503	BRACKET - LEFT	1
G (R)	100504	BRACKET - RIGHT	1
H (L)	100568	BRACKET COVER LARGE - LEFT	1
H (R)	100596	BRACKET COVER LARGE - RIGHT	1
I (L)	100569	BRACKET COVER SMALL - LEFT	1
I (R)	100597	BRACKET COVER SMALL - RIGHT	1
J	100008	TOWELMATE	1
K	100802	3/8 X 3-1/4" HEX CAP SCREW	4
L	100011	3/8 NYLON LOCKNUT	5
M	100012	3/8 FLAT WASHER	5
N	100013	#10 X 5/8" SELF TAPPING SCREWS	12
O	100027	#12 X 2" MOUNTING SCREWS	24
P	100031	3/8 CARRIAGE BOLT	1
Q	100016	SMALL BLACK DOME CAP	16
R	100244	5/16 BALL STUD	4
S	100032	5/16 NYLON LOCKNUT	4
T	100033	CMIII RUBBER STOP	2
U	100034	HEX PLASTIC DOME CAP	2
V	100035	3/8" RUBBER SLEEVE	1
W	100804	CMIII METAL PLATE	1
X	100370	PLASTIC SPACER	1
Y	100274	WIND LOCK BAR	1
Z	100245	SHOCK-CMIII	2
AA	100015	LARGE BLACK DOME CAP	2